

PLASTER FLANGE OPTIONS

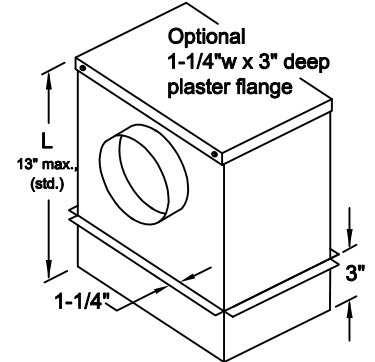

DUCT TRANSITION INLET OPTIONS / LIMITATIONS

ROUND INLET

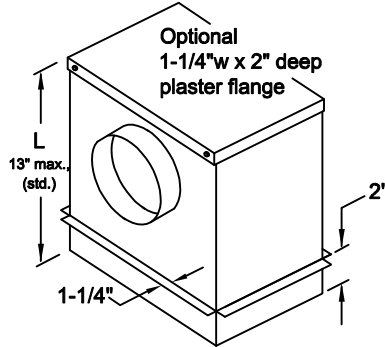
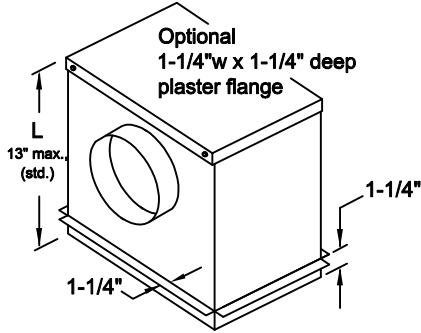
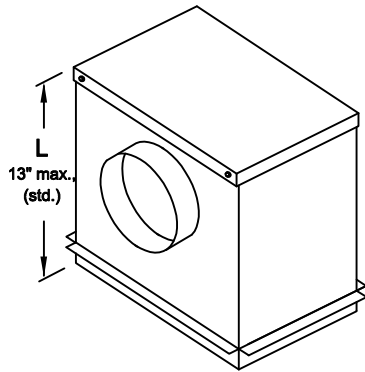

8"Ø maximum round inlet size, 9"Ø and up will be oval equivalent due to 13" max "L" dimension limitation

RECTANGULAR INLET

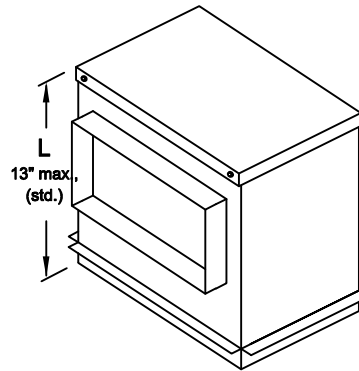

Note: Maximum inlet area can not exceed 76.12 sq. inches

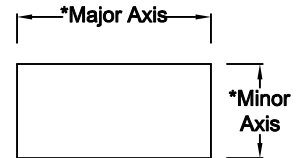

OVAL INLET

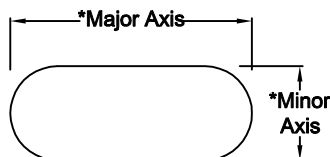
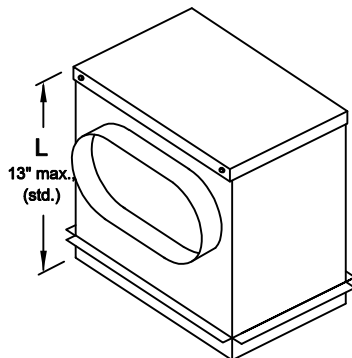

Note: Maximum inlet area can not exceed 76.12 sq. inches (max. 12" Ø oval equivalent)

Round Inlet Size	Oval Conversion Size Major Axis x Minor Axis
4"	4 ⁷ / ₁₆ " x 3 ¹ / ₄ "
5"	6" x 3 ¹ / ₄ "
6"	6 ¹ / ₄ " x 5 ¹ / ₄ "
7"	8" x 5 ¹ / ₄ "
8"	9 ³ / ₈ " x 5 ¹ / ₄ "
9"	11 ¹ / ₈ " x 5 ¹ / ₄ "
10"	12 ¹ / ₂ " x 5 ¹ / ₄ "
12"	15 ⁵ / ₈ " x 5 ¹ / ₄ "

C-SR-WT(S) OPTIONS

DRAWN BY: CLJ	DATE: 5-1-14	REV. DATE: 6-19-14
REV. NO. 1	APPROVED BY: BGT	DWG. NO.: P-93c